



BSSC **RADIATORS** EST. 80

COMPANY PROFILE

41
YEARS
1980 - 2021



MANUFACTURE | REPAIRS | SALES | SERVICES
RADIATORS | INTER-COOLERS | VARIOUS OIL COOLERS | HEAT EXCHANGERS | FANS







CONTACT DETAILS

Reception:

 Tel: +27 (0)11 892 1312
 Fax: +27 (0)11 892 5943
 @ reception@bsscradiators.co.za

Admin:

 Tel: +27 (0)11 892 1312
 Fax: +27 (0)86 657 3698
 @ admin@bsscradiators.co.za

Address:

 20 Turf Road
Anderbolt
Boksburg
South Africa

Website:

 www.bsscradiators.co.za

COMPANY PROFILE
VERSION 1.0



BSSC RADIATORS (PTY LTD)

TABLE OF CONTENTS

	PAGE
01 OUR COMPANY	4
02 OUR CLIENTS & SERVICES	5
03 SERVICE EXCHANGE PROGRAM	6
04 RESEARCH AND DEVELOPMENT	7
05 GENERAL PRODUCT OVERVIEW	8
06 AIR-CONDITIONING PRODUCTS AND PARTS	9
07 REMOVABLE TUBE TYPE CORE	10
08 WORLD OF ALUMINIUM	11
09 HEAT EXCHANGER DIVISION	12
10 INDUSTRIAL COOLING PACKS	13
11 CERTIFICATION	14
12 HALL OF FAME	15

OUR COMPANY

ABOUT US



Welcome to BSSC Radiators, a privately owned and proudly South African company founded in 2009, with industry experience dating back to the late 1980s and still owned by the Bennett family.

Continued development has transformed the company into a market leader in the field with over 40 years of abounding and diverse service in the mining industry.

We specialise in a wide range of heat-transfer products and services.

Our competitive advantage is our industry knowledge, solutions-focused approach, and commitment to personalised services, quality standards, the latest innovative practices and reliability, allowing our customers and strategic partners to feel reassured with our complete turnkey capability.

OUR ICONOGRAPHY

ILLUSTRATED IN 3 PILLARS



QUALITY



HEALTH & SAFETY



ENVIRONMENTAL
STANDARDS

VISION STATEMENT

- ✓ Remain a market leader in the heat-transfer industry.
- ✓ Constantly strive to develop more efficient cooling solutions.
- ✓ An uncompromising determination to achieve a 'first time, every time' ethos.

MISSION STATEMENT

- ✓ To provide high-grade solution-based heat transfer products for our clients' requirements.
- ✓ To design heat-transfer products that will improve the cooling system capabilities for a high output and long-lasting lifespan.
- ✓ To maximise customer satisfaction by providing a superior service to our clients in a timely and personalised manner.

"WHERE FAMILY AND BUSINESS COME TOGETHER"



PROUDLY SOUTH AFRICAN

BSSC RADIATORS (PTY) LTD IS AN APPROVED MEMBER OF PROUDLY SOUTH AFRICAN



OUR CLIENTS

WE PRIDE OURSELVES IN CUSTOMER SERVICE WITH AN EXTENSIVE FOOTPRINT WITHIN SOUTH AFRICA.



We supply products and services to the following industries and sectors:

- ✂ Mining & Earthmoving
- 🌲 Forestry
- 🚛 Plant Hire & Contractors
- 🚚 Transportation
- 🏭 Industrial
- 🔥 Gas & Oil
- 🚂 Locomotive
- 👤 Various OEMs
- 🌾 Agricultural
- 🏠 Other Radiator Outlets

OUR SERVICES



01. COLLECTION & DELIVERY SERVICES

On-site collection and delivery.



02. BREAKDOWN - "RADIATOR 911"

We provide a 24/48-hour turnaround time service within our capacity.



03. FIELD SERVICE

Our standby team is available 24/7 to provide on-site breakdown services.



04. SERVICE EXCHANGE - PEX COMPONENTS

We have a wide range of complete cooling packs available.

WARRANTY

Application	Type of Core	Repairs	Re-cores
On-Road	Conventional - Copper / Aluminium / Steel	12 Months	12 Months
Off-Road	Conventional - Copper / Aluminium / Steel	6 Months	6 Months
	Removable Tube - Copper / Aluminium	60 Months	60 Months
	Folded / Modular / Segmented	6 Months	6 Months

ALL WARRANTY PERIODS START FROM DATE OF INSTALLATION



SERVICE EXCHANGE PROGRAM

"AN INNOVATIVE FLEET MAINTENANCE SOLUTION"

YOUR SATISFACTION IS OUR COMMITMENT

BSSC Radiators is dedicated in providing our clients with heat transfer solutions for over 40 years. Our service exchange program enables our clients to have immediate access to a heat transfer solution for planned maintenance or emergency breakdown services.

PLANNED MAINTENANCE PROGRAM

Fast-track your equipment repairs, minimize risk, and shorten your downtime with our service exchange program and avoid costly part availability issues, which has become a common problem in the mining industry.

- ✓ Effectively reduce mining equipment downtime
- ✓ Easier and safer maintenance for your fleet
- ✓ Guaranteed availability for planned maintenance
- ✓ Service exchange components on site ready for changeout

EMERGENCY BREAKDOWN SERVICES "RADIATOR 911"

In emergency breakdown situations, our service exchange components are available for immediate delivery to site. In the event of insufficient stock availability, a 24/48-hour turnaround service within our capacity will be provided on a breakdown bases.

SERVICE EXCHANGE PRODUCTS AND PARTS

BSSC Radiators have a comprehensive range of service exchange radiators, inter-coolers, various oil coolers, complete nosecone units, cooling packs and fans. As the demand continues to grow for this service, so does our range of service exchange parts.



**CAT 994H
NOSEPHONE UNIT**

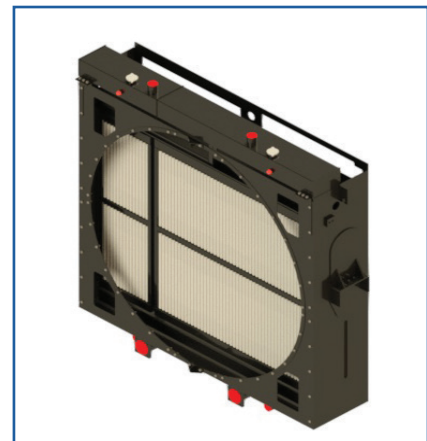

**CAT 994H
COMPLETE COOLING PACK**

OUR SERVICE EXCHANGE PROCESS



RESEARCH & DEVELOPMENT

"OUR HEAT-TRANSFER ENGINEERS HAVE THE SOLUTION FOR YOU"

ENGINEERING

Our engineering team draws on more than 40 years of experience servicing the mining industry, ensuring delivery of the most efficient product, designed and manufactured to customer specifications.

Taking your design specifications and our application knowledge, we develop each product as a fit-for-purpose solution, that meets all our clients' thermal requirements. Irrespective of the duty or application, we have the experience to optimise the heat transfer product for you.

DESIGN - ADDING VALUE TO EVERY BLUEPRINT

We mechanically design every new heat transfer package using 3D AutoCAD Software. As part of the '5-step' process, we supply a 3D model to our customers for integration into their own designs. This resolves fitment delays when the final product is installed on-site, offering a complete 'turnkey' solution.

We have invested significantly in our capability for value engineering and optimising designs for cost, manufacture, reliability, operation, and serviceability. This manifests in our professional and user-friendly products.

IN-HOUSE

- ✔ Dedicated drawing department
- ✔ Qualified draftsmen
- ✔ Various coded welders
- ✔ Full-fledged machine shop

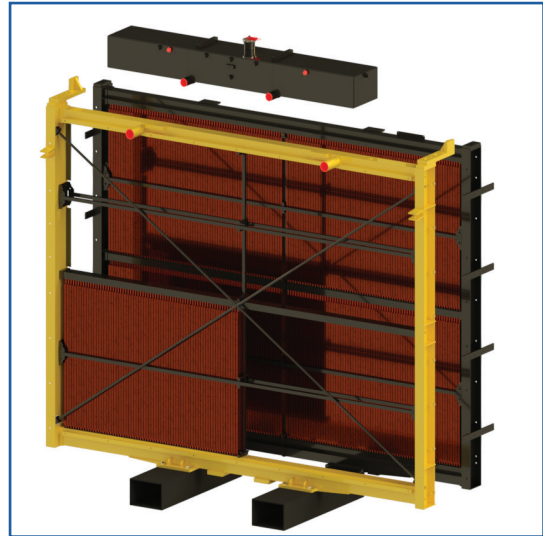

**KOMATSU 960E-1/2 COOLING PACK
AUTOCAD EXPLODED RENDERING**

MANUFACTURING - WE'VE MADE PASSION OUR RAW MATERIAL

Our in-house fabrication capacity enables us to produce complex products with a high degree of quality control and short lead times as part of our solutions offering.

We can reliably produce customised products in low volumes while meeting all necessary compliance requirements, including material and dimensional specifications for our customers.

WELDING - WE OFFER A WIDE RANGE OF FULLY COMPLIANT ENGINEERED SOLUTIONS

We have developed a vast array of qualified welding procedures and welders to support a wide variety of products. We can comply with project-specific standard requirements, be they international or local applications for specific vibration, durability, performance, corrosion protection and safety.

INSTALLATION, TESTING & COMMISSIONING

Our specialised heat transfer engineers offer an 'end-to-end' service experience beginning with the testing of your plant and equipment to understand the performance and upgrade options available, through to the installation and commissioning of the heat transfer system.

END-TO-END PROCESS



GENERAL PRODUCT OVERVIEW

VARIOUS AUTO-MOTIVE COOLERS

- Transmission Oil Coolers
- Hydraulic Oil Coolers
- Engine Oil Coolers
- Fuel Coolers



TUBE AND SHELL COOLERS

For both in-plant and mobile equipment

STANDARD OPERATING PRESSURES

Shell Side: (1000kPa)
Tube Side: (350kPa)

MAXIMUM TEMPERATURE

Water: 110°C
Oil: 135°C

ADVANTAGES:

- High pressure
- Various configurations of length and dimension
- Available in corrosion-resistant materials

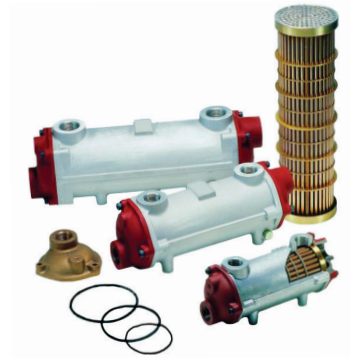

'4 STEP' CLEANING PROCESS



HIGH PRESSURE
FLUSH



CHEMICAL
CLEAN



ULTRA SONIC
CLEAN



HYDRAULIC
SHOCK LOADING

COMPRESSOR OIL COOLERS

BSSC Radiators have the necessary specialised in-house testing facilities available to successfully test compressor oil coolers.

INTER-COOLERS | AFTER-COOLERS

BSSC Radiators specialises in a wide range of aluminium Air-Air products.

CONFIGURATIONS		TYPE
OPTION 1	PLASTIC TANKS/ALUMINIUM CORE	CRIMP ON
OPTION 2	COMPLETE ALUMINIUM UNIT	WELD ON



"KEEPING IT COOL UNDER PRESSURE"



AIR-CONDITIONING PRODUCTS AND PARTS

We supply new complete parts to OEM specifications

CONDENSERS

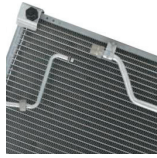

POLLEN FILTERS



COMPRESSORS



GAS R134A / R1234YF



EVAPORATORS



ACCESSORIES AND TOOLING



FAN DIVISION

We specialise in a wide range of earth moving fans, manufactured and repaired to OEM specifications.

TYPE	SUPPLY / SERVICE	BALANCING
STEEL	NEW COMPLETE, RE-BLADE OR RECONDITION	BALANCING REPORT
MULTI-WING	NEW COMPLETE, RE-BLADE OR RECONDITION	
VISCOUS-CLUTCH	NEW COMPLETE	N/A



STEEL



VISCOUS-CLUTCH



MULTI-WING

ACCESSORIES

RAM manufactures and supplies quality automotive belts, hoses and accessories to the replacement aftermarket.

OFFICIAL DISTRIBUTORS OF



LEVER-VENT RADIATOR CAP



PRESSURE TEST KIT



ANTI-FREEZE



HOSES



COMBUSTION TEST KIT

WE OFFER ON-SITE TRAINING FOR THE ABOVE ACCESSORIES

REMOVABLE TUBE-TYPE CORE

BSSC RADIATORS REMOVABLE TUBE-TYPE CORE IS DESIGNED AND MANUFACTURED TO **“OUTLAST THE ENGINE IN WHICH IT COOLS”**

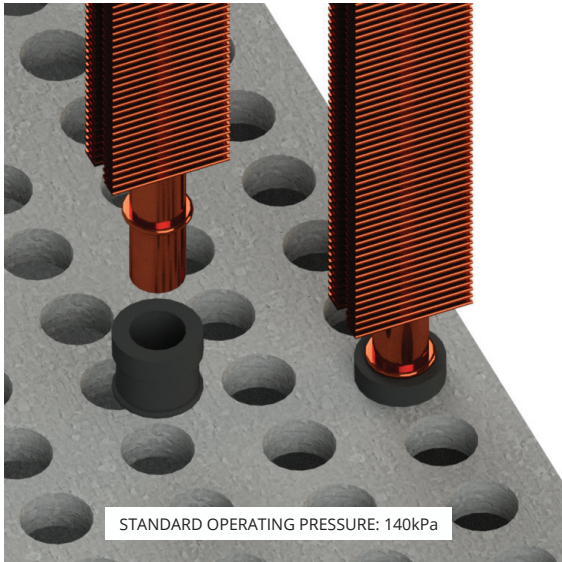

STANDARD OPERATING PRESSURE: 140kPa

STANDARD COPPER REMOVABLE TUBE

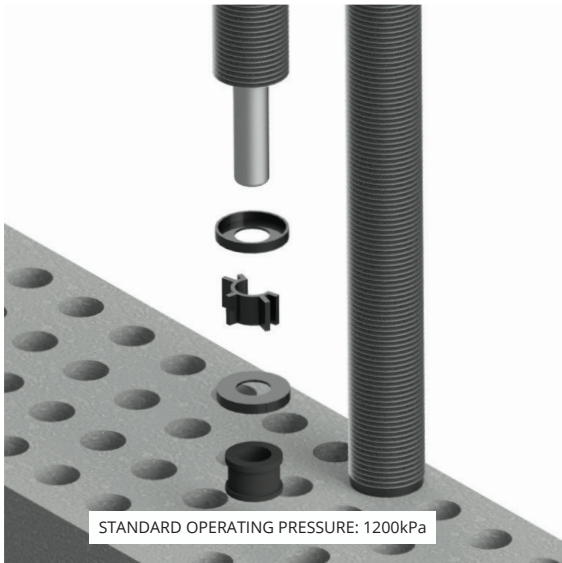

STANDARD OPERATING PRESSURE: 1200kPa

SPIRAL ALUMINIUM REMOVABLE TUBE

ADVANTAGES

ON-SITE REPAIRABLE TO 100% COOLING CAPACITY

The removable tube is field-repairable and capable of being returned to 100% cooling capacity on-site often without having to remove the radiator out of the machine, saving on downtime and labour cost.

FLEXIBLE GENUINE VITON GROMMETS

Individual cooling tubes are fitted in galvanised header-plates with genuine Viton grommets. Grommets absorb vibration, stresses and thermal shock which cause rigid soldered seams to crack and leak.

Maximum temperature: 250°C

LOW MAINTENANCE

Tubes are arranged to create open passages so dirt and debris can blow through the core either with high pressure water or air.

RETROFIT INSTALLATION

Convert your cooling pack to the removable tube-type core and save.

OVERVIEW

- ✓ FLEXIBLE GENUINE VITON GROMMETS
- ✓ RETROFIT INSTALLATIONS
- ✓ 5-YEAR WARRANTY
- ✓ LOW MAINTENANCE
- ✓ ON-SITE REPAIRABLE





WORLD OF ALUMINIUM

WE SPECIALISE IN ALUMINIUM IN-HOUSE WELDING AND MANUFACTURING OF VARIOUS CORES, TANKS, AND FRAMEWORK.

LIST OF ALUMINIUM PRODUCTS

- OIL COOLERS
- HYDRAULIC OIL COOLERS
- TRANSMISSION OIL COOLERS
- RADIATORS
- INTER-COOLERS
- AIR-CONDENSERS

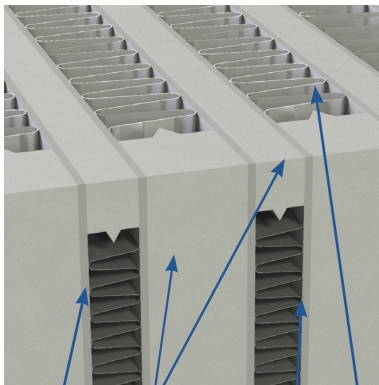

SUPPORTING PLATE SIDE BAR TURBULATED TUBE COOLING FIN

BAR AND PLATE ALUMINIUM

Features and benefits include:

The bar and plate configuration is extremely robust and resistant to external damage. It can withstand extreme operating pressures and offers superior heat-transfer capabilities.

Standard Operating Pressure: 3000kPa
Maximum Temperatures: 220°C

ADVANTAGES:

- ✓ EXTREMELY ROBUST
- ✓ HIGH PRESSURE HANDLING
- ✓ SUPERIOR HEAT-TRANSFER CAPABILITIES

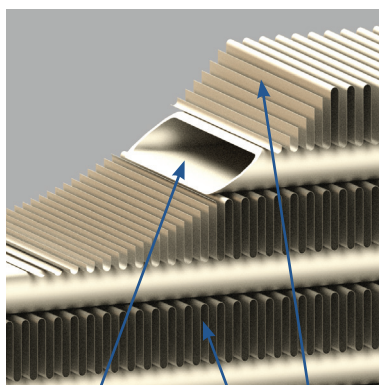

HOLLOW SEAMLESS TUBE LOUVRES CORRUGATED LOUVRED FIN

TUBE AND FIN ALUMINIUM

Features and benefits include:

The tube and fin aluminium configuration is extremely lightweight, and is offered in multiple row and fin density combinations, to provide less clogging and optimise system performance, whether a welded or extruded tube application.

Standard Operating Pressure: 100kPa
Maximum Temperatures: 220°C

ADVANTAGES:

- ✓ LIGHTWEIGHT
- ✓ LESS CLOGGING

"OUR PRIORITY LIES IN OUR COOLING"



HEAT EXCHANGER DIVISION

BSSC Radiators specialises in the manufacturing, reconditioning, and repairing of various in-plant heat exchanger components.

SHELL & TUBE HEAT EXCHANGERS



DOUBLE PIPE HEAT EXCHANGERS

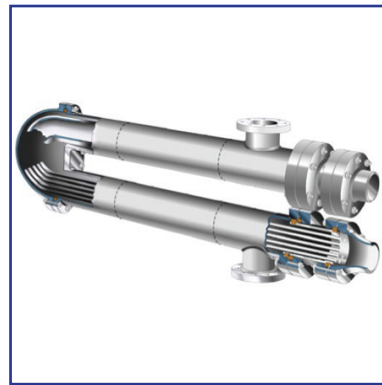

AIR BLAST HEAT EXCHANGERS



GASKETED PLATE HEAT EXCHANGERS

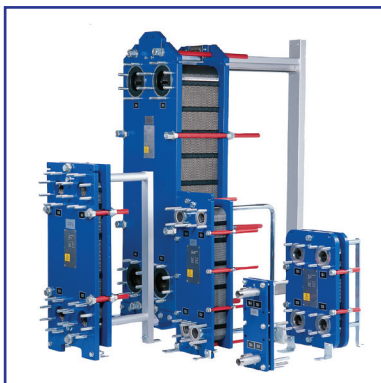

PLATE HEAT EXCHANGERS



INDUSTRIAL COOLING PACKS

BSSC Radiators specialises in the manufacturing, reconditioning, and repairing of various heat transfer components found in stationary and mobile equipment.

INDUSTRIAL GENERATOR SETS

OPEN SET



CLOSED SET | SILENT TYPE



INDUSTRIAL COOLING PACKS

INDUSTRIAL AIR COMPRESSOR



INDUSTRIAL LIGHT TOWER



INDUSTRIAL WATER PUMP



MOBILE FORKLIFTS



INDUSTRIAL CRUSHERS



CERTIFICATION

CERTIFICATE

Standard: ISO 9001:2015
 Certificate Registr. No.: 01 100 928548

Certificate Holder: TÜV Rheinland Inspection Services Certifies:
BSSC Radiators (Pty) Ltd
 20 Turf Road
 Anderbolt
 Boksburg, 1459
 Capetown
 Republic of South Africa

Scope: Manufacture and reconditioning of radiators, various oil coolers and heat-exchangers.

Validity: An audit was performed, Report No. 928548. Proof has been furnished that the requirements according to ISO 9001:2015 are fulfilled.
 The due date for all future audits is 23 - 05 (dd.mm).
 The certificate is valid from 2020-07-18 until 2023-07-17 First Certification 2017

 South Africa, 2020-07-28 TÜV Rheinland Inspection Services (Pty) Ltd
 92 Koranna Avenue
 Dorningford
 Centurion
 0146
 Certification Body No. C09



www.tuv.com Precisely Right.

TÜV RHEINLAND ISO 9001 CERTIFICATION

SABS

Certificate of Registration

This is to certify that

BSSC RADIATORS (PTY) LTD
 Co Reg. 2012/093480/07
ANDERBOLT, BOKSBURG

has been assessed and found to satisfy the requirements of

SANS 10276:2005
MOTOR VEHICLE RADIATOR RECONDITIONING WORKSHOPS

in respect of

THE MANUFACTURING AND RECONDITIONING OF RADIATORS AND COOLERS

This certificate, including the schedule which forms an integral part thereof -
 - is issued without reservation
 - is identified by the applicable registration number
 - is subject to any condition or limitation contained therein
 - is valid subject to ongoing compliance with certification requirements
 - shall be reviewed by SABS Commercial Ltd. in the absence of the audit the certificate and the certificate shall be, in whole, void
 - the certificate may be automatically withdrawn if the holder or "Certified Client" on the SABS Commercial website (www.sabs.co.za)

Registration Number	LRR 3
Effective Date	30 March 2020
Expiry Date	19 April 2023
Date of Original Registration	20 April 2017
Chief Executive Officer	

SABS COMMERCIAL (Pty) Ltd
 10001 10171-04 - 10170, 10170 and 10171 are registered trademarks. Unauthorised reproduction is prohibited.

SABS ISO/SANS 10276 CERTIFICATION



CERTIFICATE OF MEMBERSHIP

THIS IS TO CERTIFY THAT

Bssc Radiators (Pty) Ltd

has satisfied the criteria for membership and has therefore been accredited as a

Member

of Proudly South African, entitled to identify the organisation's qualifying products and services as Proudly South African

Member since: 14/11/2019 To: 16/11/2021

Membership category: Member Membership number: C03947

Chief Executive Officer:  Date: 24/11/2020

PROUDLY SOUTH AFRICAN CERTIFICATION



MARISIMO DUE DILIGENCE INVESTIGATIONS (PTY) LTD
 2012/JAN/07
 518 Farm Road, the Village 0041
 Tel: 081 463 3277 Email: admin@marisimo.co.za

BSSC RADIATORS (PTY) LTD

Due Diligence Report No: SQ101ME

This report confirms the information contained in the sworn affidavit attached hereto.
 This affidavit was deposed to by Derek M Bennett, Director.

- CONFIRMATION OF BUSINESS PROFILE**

Registration No:	2012/093480/07
VAT No:	402029215
Head Office Address:	20 Turf Road, Anderbolt, Boksburg
- CONFIRMATION OF B-BBEE STATUS**

Government Gazette	36928	Black Ownership	51%
Category of Enterprise	QSE	Black Women Ownership	51%
Broad Based BEE Status Level	LEVEL 2	Employment Suppliers	YES
Procurement Recognition Level	1.95%	Designated Group Supplier	NO
- THE FOLLOWING DOCUMENTS WERE ASSESSED IN ORDER TO CONFIRM THE INFORMATION AS STATED ABOVE:**

BUSINESS PROFILE	CIPC registration Financial statements for financial period 1 March 2018 – 28 February 2019 VAT Registration Letterhead Share Option Agreement Share Option Certificate
B-BBEE STATUS	Share Certificates of all shareholders Confirmation of registration of NPC NPC Rules Memorandum of Incorporation of NPC Confirmation of NPC Beneficiaries: Beneficiary Register Certified ID Copies of Beneficiaries

Although the above-mentioned level of turnover/income is correct, the level of turnover/income is closely related to the economic indicators and may be more or less in future. Consequently, this report does not serve as a guarantee that the income reflector will continue at the same level.
 This report is an independent assessment by a competent person of the contents of an affidavit submitted by the deponent in terms of the Codes of Good Practice on Black Economic Empowerment/Supplier Codes relevant to the entity as the case may be.
 This report is only of value if accompanied by an affidavit as required by the relevant Codes of Good Practice.
 All relevant information and documents obtained by Marisimo Due Diligence will be kept for a period of 12 months.
 Marisimo Due Diligence does not guarantee that this report will lead to any particular outcome or result, and do not accept any responsibility for any false documents or information presented to us.

 M.A Vorster
 Attorney, Supreme Court of S.A.
 Date of issue: 05 JUNE 2020
 Expiry date: 05 JUNE 2021
 Period of validity: 12 months

Copyright reserved Marisimo Due Diligence Investigations (Pty) Ltd

LEVEL 2 B-BBEE CERTIFICATION

HALL OF FAME

COMPLETE REBUILD



KOMATSU 960E-1/2
BEFORE

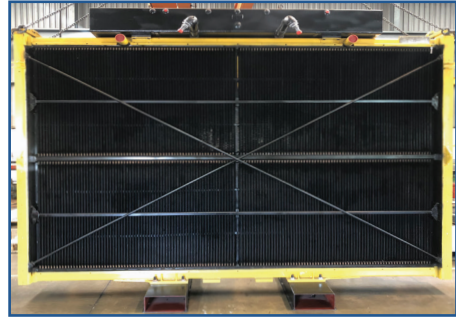

KOMATSU 960E-1/2
AFTER

CONVERSION



HITACHI EH 5000AC-3
BEFORE

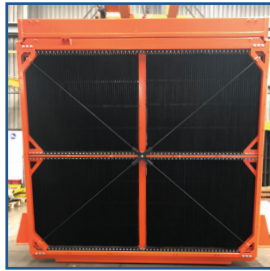

HITACHI EH 5000AC-3
AFTER



HITACHI EX 5500-6
BEFORE

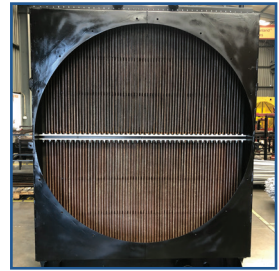

HITACHI EX 5500-6
AFTER

RE-CONDITION / RE-CORE

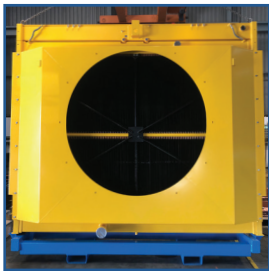

TEREX MT 4400
AFTER



JOY-GLOBAL L2350
AFTER



KOMATSU 930E
AFTER



CAT 793D
AFTER



CAT 777F
AFTER

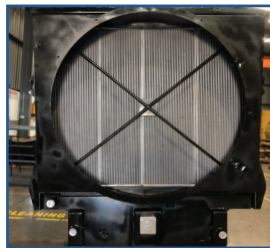

KOMATSU 785-7
AFTER

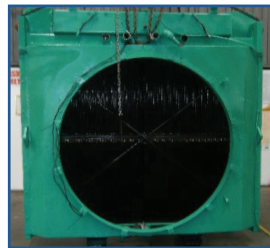

KOMATSU 730E
AFTER

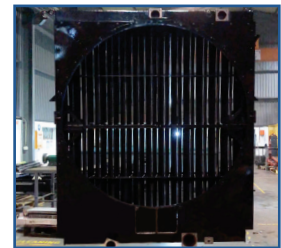

CAT 789D
AFTER



Visit our website at
www.bsscradiators.co.za